

# VERSION

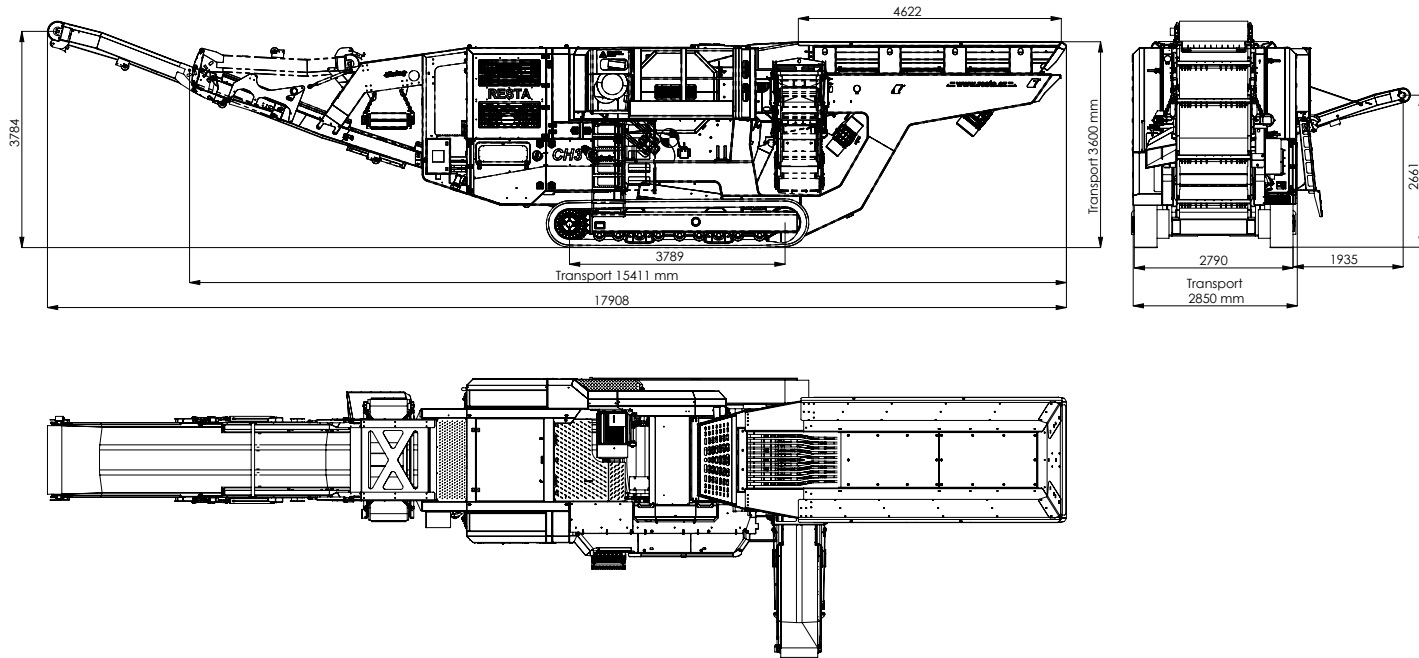

## RESTA CH3G 1100x750

Mobile jaw crusher

### RESTA s.r.o.

**Contact:**

Kojetínská 3120/75  
750 02 Přerov  
Czech Republic

+420 581 741 811  
Fax +420 581 299 958  
rest@resta.cz

[www.resta.cz](http://www.resta.cz)

**Company identification:**

CRN: 14616807  
TIN: CZ14616807

GPS: 49.4435458 N, 17.4361281 E

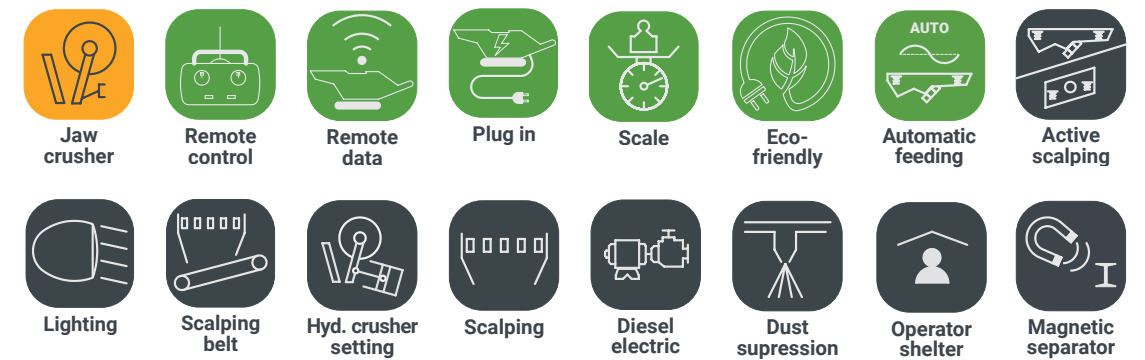
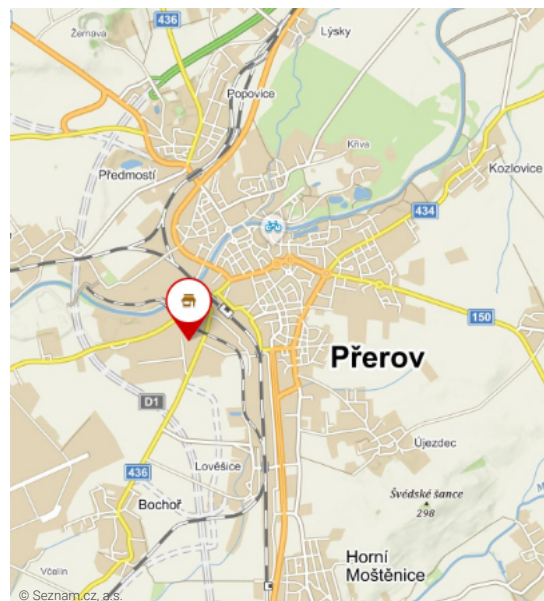

<b>Max. feed size</b>	900x700x600 mm
<b>Final product</b>	0-90 mm, 0-250 mm (according to crusher setting)
<b>Troughput</b>	90-300 t/h
<b>Hopper</b>	5-7 m³
<b>Weight</b>	50 t

### DESIGNED FOR:

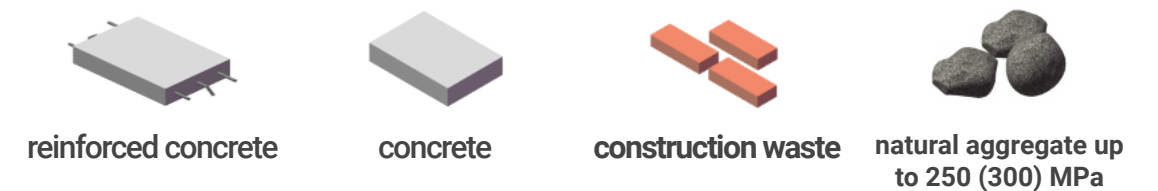

RESTA s.r.o.  
CRN: 14616807  
TIN: CZ 14616807

Kojetínská 3120/75  
750 02 Přerov  
Czech Republic

rest@resta.cz  
+420 581 741 811

[www.resta.cz](http://www.resta.cz)



RESTA s.r.o.  
CRN: 14616807  
TIN: CZ 14616807

Kojetínská 3120/75  
750 02 Přerov  
Czech Republic

rest@resta.cz  
+420 581 741 811

[www.resta.cz](http://www.resta.cz)





### Operation

- ✓ semi-automatic control
- ✓ easy and safe access to all operation and service points
- ✓ operator shelter option

### Maintenance and service

- ✓ clean compact design
- ✓ easy access
- ✓ simplicity

### Equipment features

- ✓ accurate proportional tracking controls
- ✓ double-speed tracking
- ✓ rapid Set-up
- ✓ dust suppression option

### Diesel genset

- ✓ low fuel consumption
- ✓ option to use external power supply
- ✓ double sealing of switchboard
- ✓ user-friendly

### Magnetic separator

- ✓ separation of magnetic pieces from the material
- ✓ reversible direction of rotation (discharge to left or right)
- ✓ adjustable overbelt height

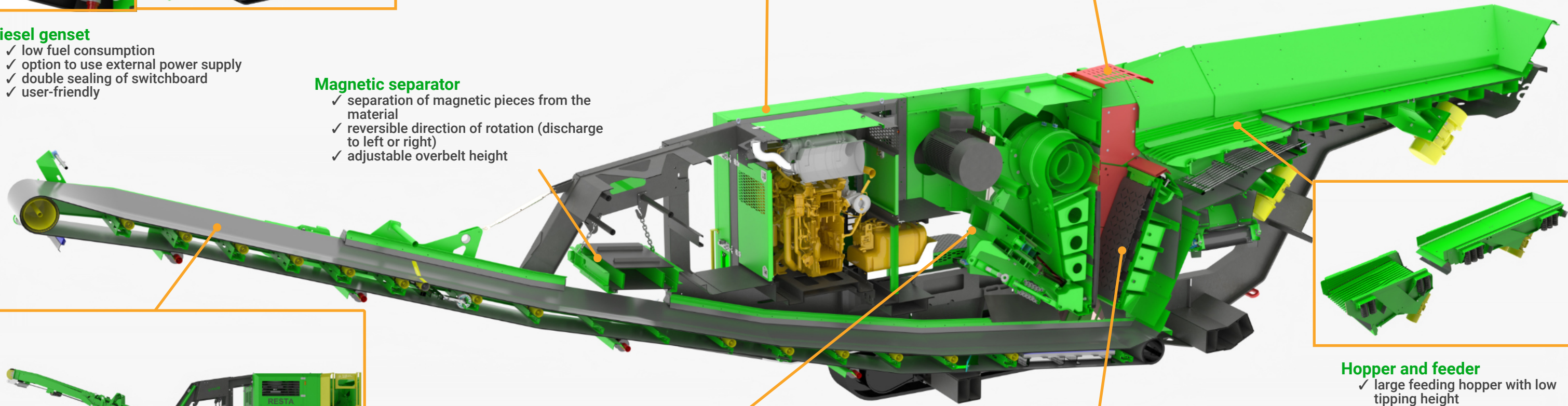

### Hopper and feeder

- ✓ large feeding hopper with low tipping height
- ✓ feeder with fluent feeding regulation
- ✓ live scalper with double-deck scalping

### Side belt for scalped product

- ✓ side belt can be swapped from side to side
- ✓ user-friendly
- ✓ in transport position, it does not restrict access to the crusher



### Product belt

- ✓ integrated scale
- ✓ transport height 3.7 m
- ✓ possibility of a folding version of the conveyor to increase throughput when crushing heavily reinforced material

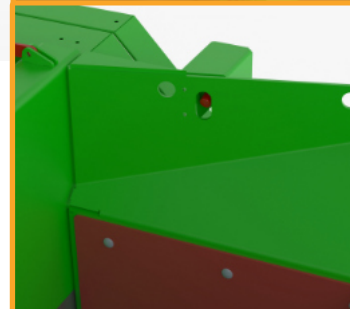

### Crusher

- ✓ low operation costs
- ✓ high operation reliability
- ✓ automatic monitoring of the crusher filling
- ✓ automatic material feeding into the crusher
- ✓ high performance and robust structure
- ✓ integrated drive
- ✓ easy replacement of spare parts
- ✓ option to hydraulically set close side

