

MODEL

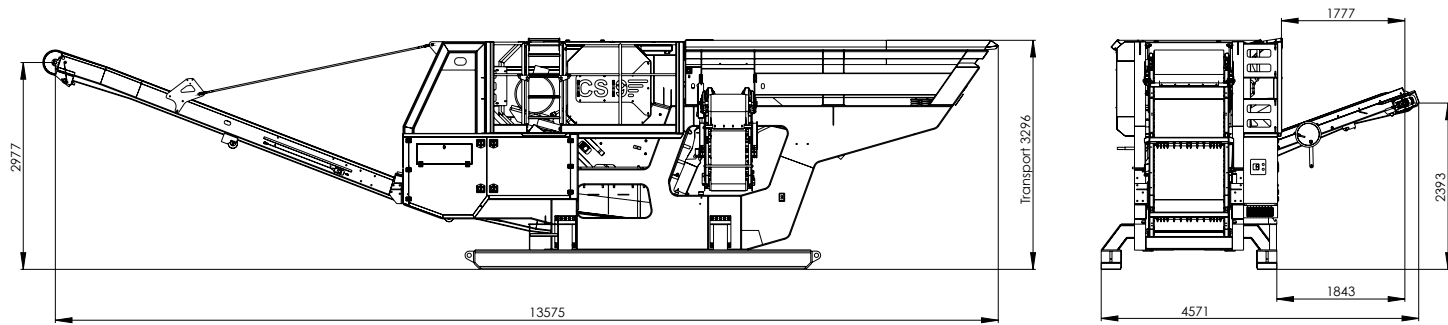

Operation



Transport

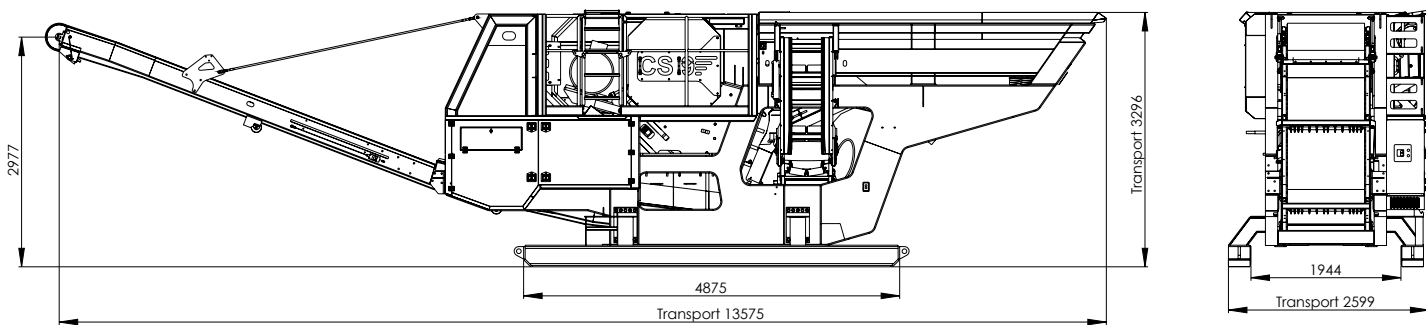

RESTA CS9 900x600

Semi-mobile jaw crusher

- Jaw crusher
- Remote control
- Remote data
- Plug in
- Scale
- Eco-friendly
- Automatic feeding
- Close side setting
- Lighting
- Scalping belt
- Hyd. crusher setting
- Scalping
- Diesel electric
- Dust suppression
- Operator shelter
- Magnetic separator

| | |
|-----------------------|--|
| Max. Feed size | 800x600x500 mm |
| Final product | 0-60 mm, 0-250 mm (according to crusher setting) |
| Troughput | 50-180 t/h |
| Hopper | 6 m ³ |
| Weight | 24 t |

DESIGNED FOR:

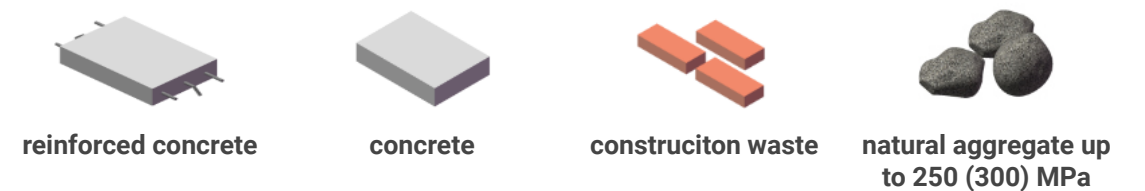

RESTA s.r.o

Contact:

Kojetínská 3120/75
750 02 Přerov
Czech Republic

+420 581 741 811
Fax +420 581 299 958
rest@resta.cz

Company identification:

CRN: 14616807
TIN: CZ14616807

GPS: 49.4435458 N, 17.4361281 E

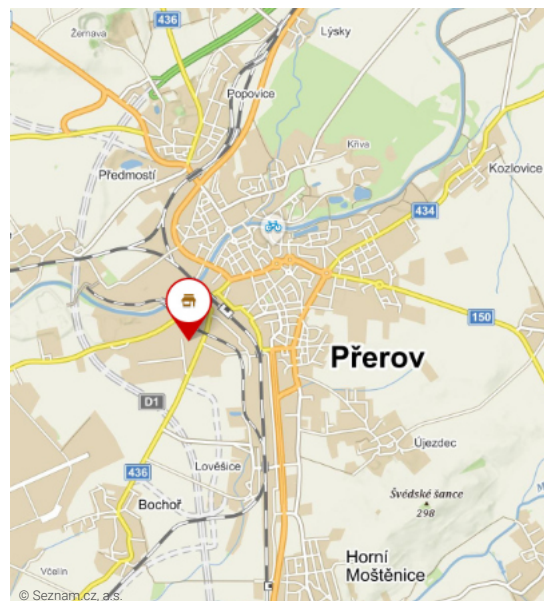

www.resta.cz



RESTA s.r.o.
CRN: 14616807
TIN: CZ 14616807

Kojetínská 3120/75
750 02 Přerov
Czech Republic

rest@resta.cz
+420 581 741 811

www.resta.cz



RESTA s.r.o.
CRN: 14616807
TIN: CZ 14616807

Kojetínská 3120/75
750 02 Přerov
Czech Republic

rest@resta.cz
+420 581 741 811

www.resta.cz

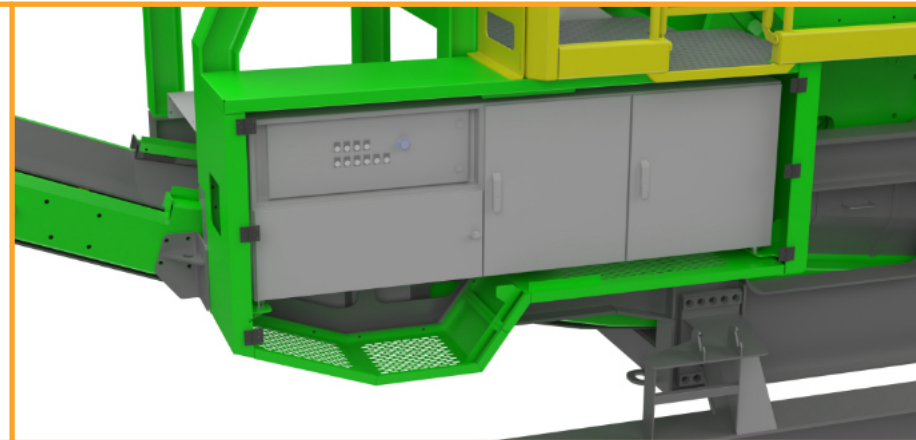
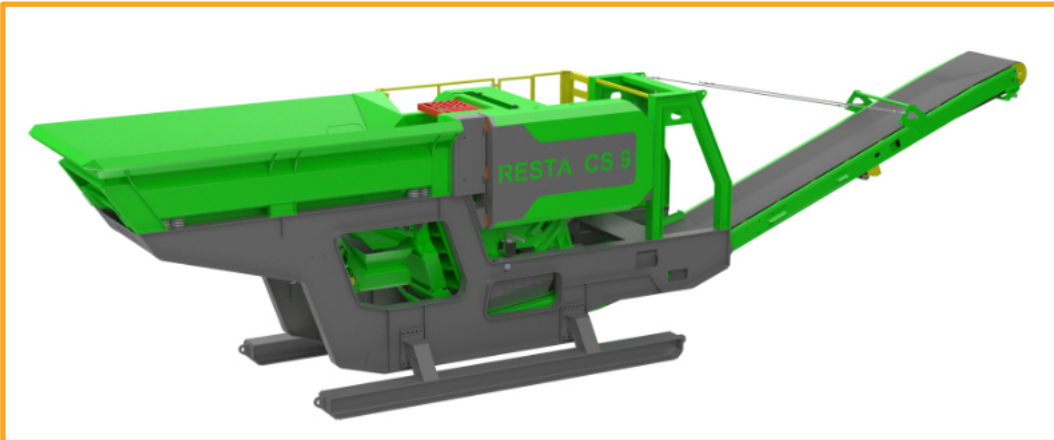

Magnetic separator

- ✓ separation of magnetic pieces from the material
- ✓ reversible direction of rotation (discharge to left or right)
- ✓ adjustable overbelt height

Maintenance and service

- ✓ clean compact design
- ✓ easy access
- ✓ simplicity

Operation

- ✓ semi-automatic control
- ✓ easy and safe access to all operation and service points
- ✓ operator shelter option
- ✓ fine proportional control of tracked undercarriage
- ✓ double-gearred undercarriage

Quarry and recycling version

- ✓ optimal efficiency
- ✓ efficient and easy crushing of reinforced concrete – recycling version
- ✓ feeding by an excavator – quarry version
- ✓ jeasy and rapid setup from transport to working position
- ✓ dust suppression for dust reduction

Hopper and feeder

- ✓ large feeding hopper with low tipping height
- ✓ feeder with fluent feeding regulation

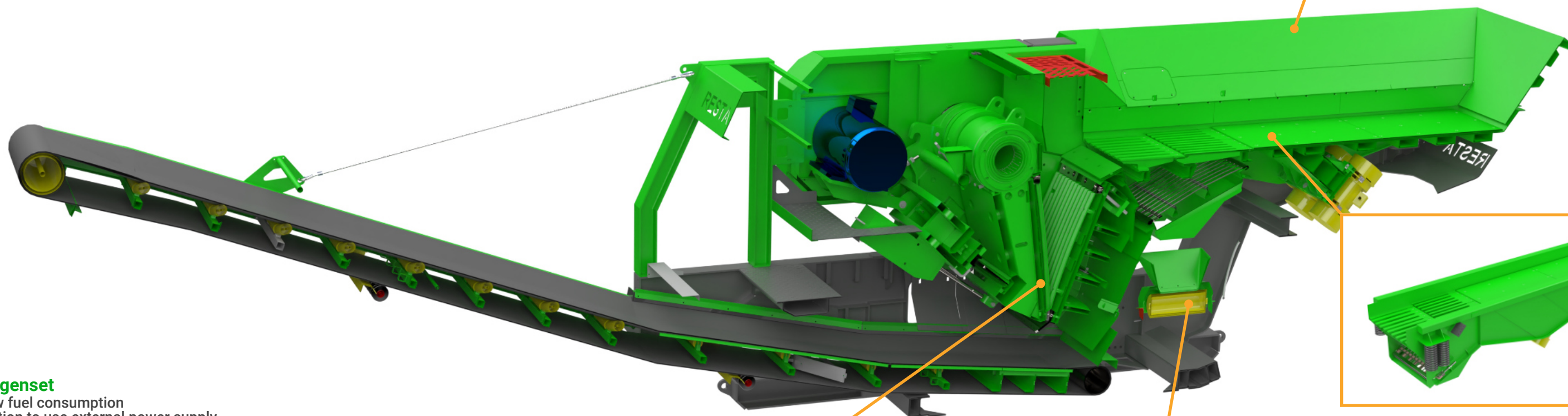

Diesel genset

- ✓ low fuel consumption
- ✓ option to use external power supply
- ✓ double sealing of switchboard
- ✓ easy maintenance

Side belt for scalped product

- ✓ side belt can be swapped from side to side
- ✓ user-friendly
- ✓ in transport position, it does not restrict access to the crusher

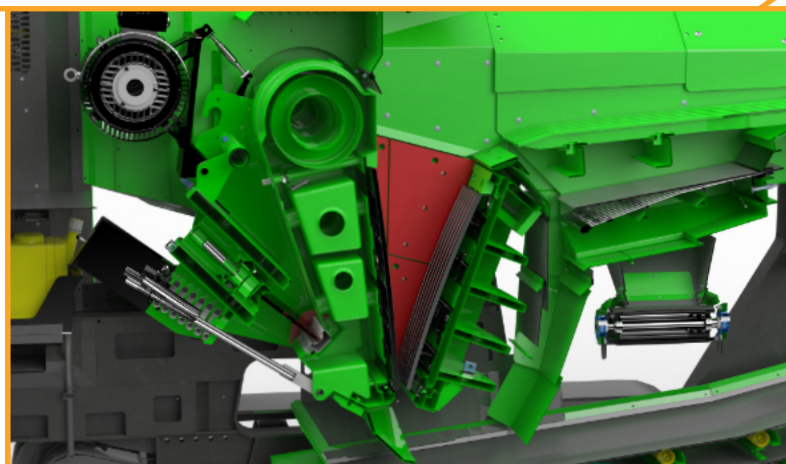

Crusher

- ✓ low operation costs
- ✓ high operation reliability
- ✓ automatic monitoring of the crusher filling
- ✓ automatic material feeding into the crusher
- ✓ high performance and robust structure
- ✓ integrated drive
- ✓ easy replacement of spare parts
- ✓ option to hydraulically set close side
- ✓ hydraulic version – automatic crusher protection when an uncrushable object gets into the crusher
- ✓ recycling version – option to mount an active iron bender for safe and efficient reinforced concrete crushing

