

MODEL

Operation

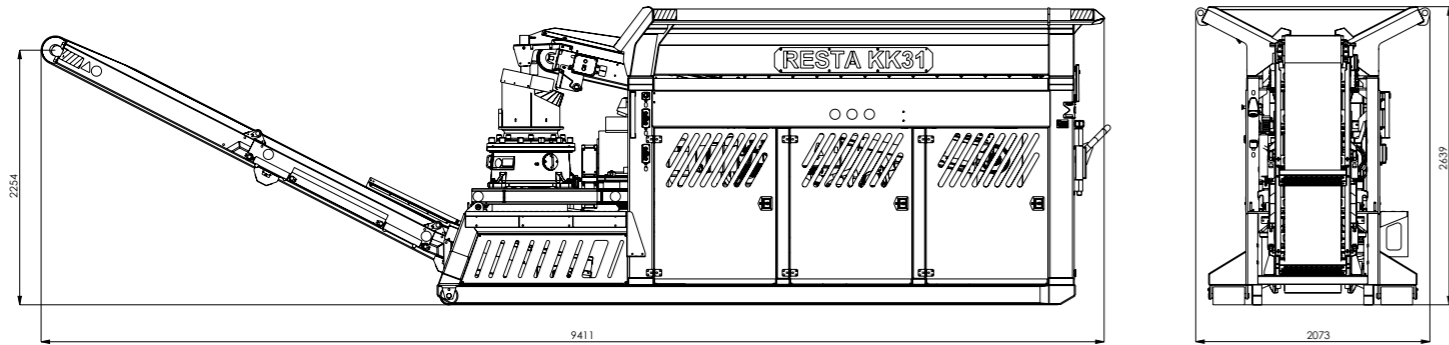

Transport

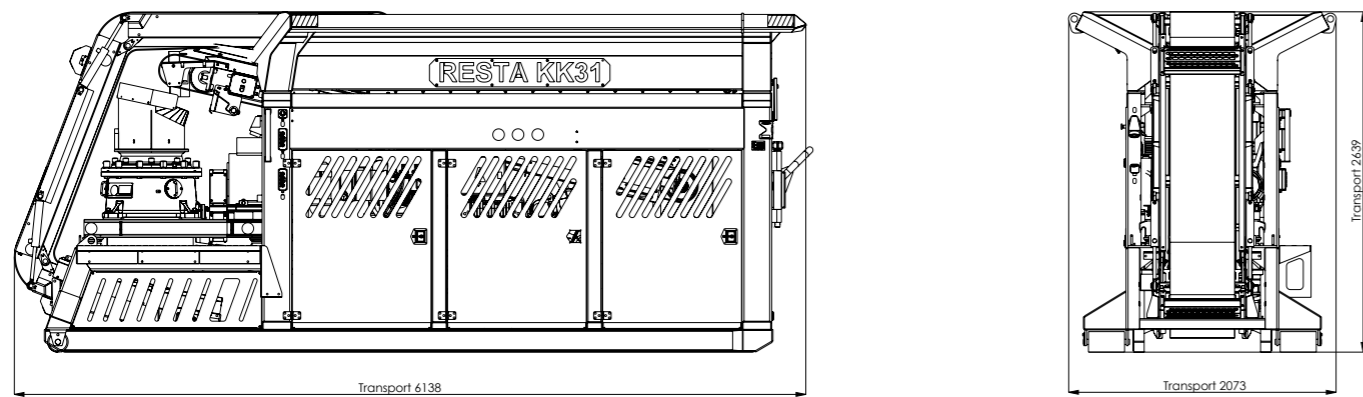

RESTA s.r.o

Contact:

Kojetínská 3120/75
750 02 Přerov
Czech Republic

+420 581 741 811
Fax +420 581 299 958
rest@resta.cz

www.resta.cz

Company identification:

CRN: 14616807
TIN: CZ14616807

GPS: 49.4435458 N, 17.4361281 E

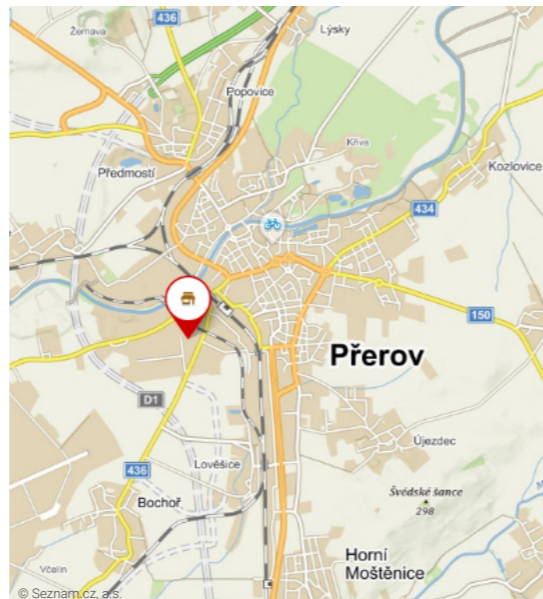

RESTA KK31
Container cone crusher

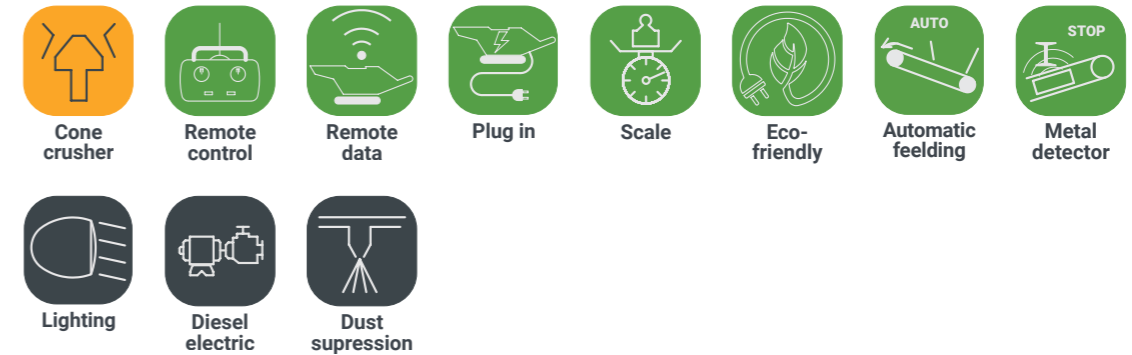

Feed size	0-63 mm
Final product	0-32 mm (according to the chosen crusher)
Throughput	5-30 t/h (according to crusher setting)
Hopper	2.5 m ³
Weight	6.5 t

DESIGNED FOR:

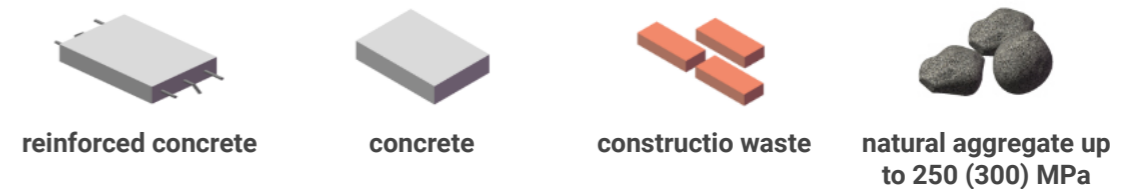

RESTA s.r.o.
CRN: 14616807
TIN: CZ 14616807

Kojetínská 3120/75
750 02 Přerov
Czech Republic

rest@resta.cz
+420 581 741 811

www.resta.cz



RESTA s.r.o.
CRN: 14616807
TIN: CZ 14616807

Kojetínská 3120/75
750 02 Přerov
Czech Republic

rest@resta.cz
+420 581 741 811

www.resta.cz



Metal detector

- ✓ crusher protection against the penetration of metallic material
- ✓ adjustable sensitivity



Transport

- ✓ carrier - DIN standards or others
- ✓ crane handling slings
- ✓ easy preparation for transport



Operation

- ✓ semi-automatic control
- ✓ easy and safe access to all operation and service points

Maintenance and service

- ✓ clean compact design
- ✓ easy access
- ✓ simplicity
- ✓ low cost on worn parts

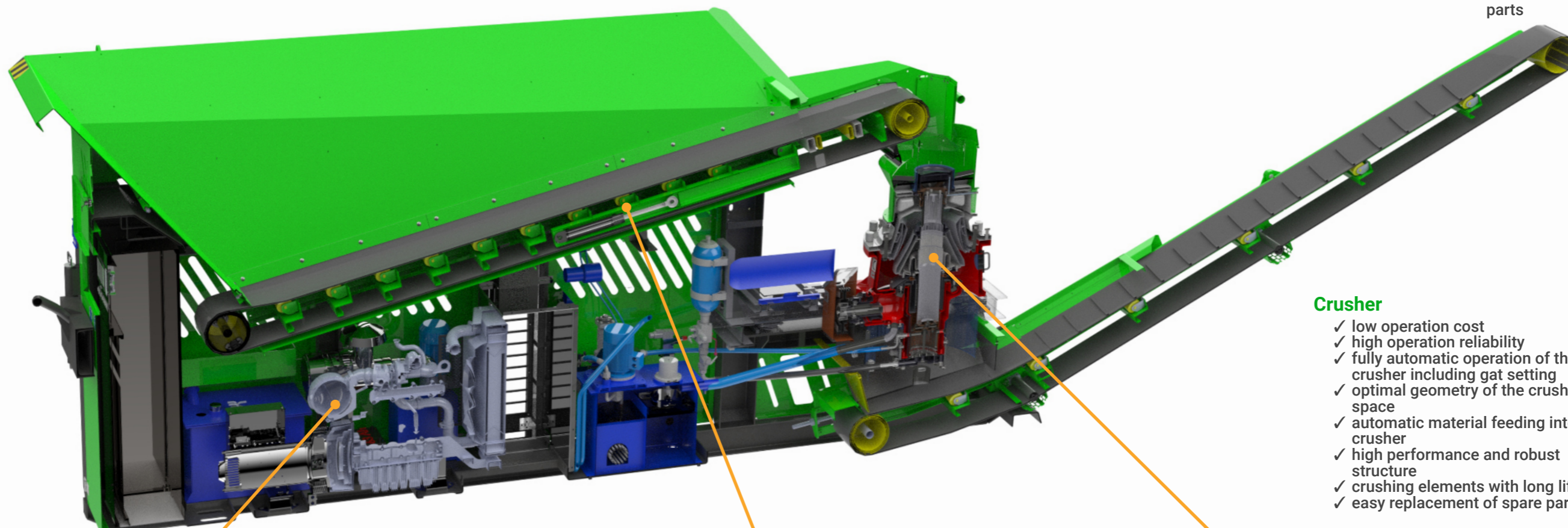

Diesel genset

- ✓ low fuel consumption
- ✓ option to use external power supply
- ✓ double sealing of switchboard
- ✓ user-friendly

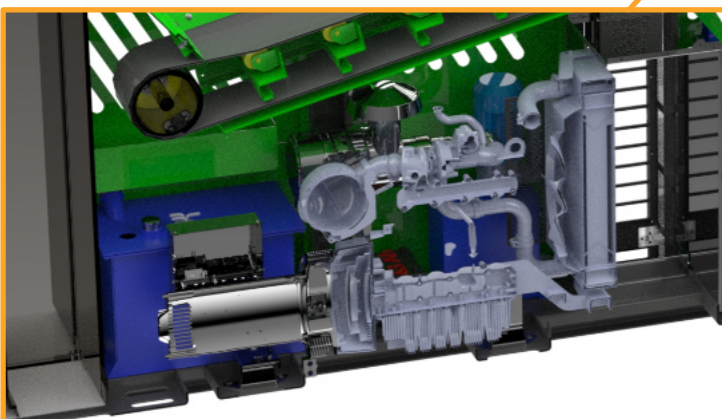

Crusher

- ✓ low operation cost
- ✓ high operation reliability
- ✓ fully automatic operation of the crusher including gap setting
- ✓ optimal geometry of the crushing space
- ✓ automatic material feeding into the crusher
- ✓ high performance and robust structure
- ✓ crushing elements with long lifetime
- ✓ easy replacement of spare parts

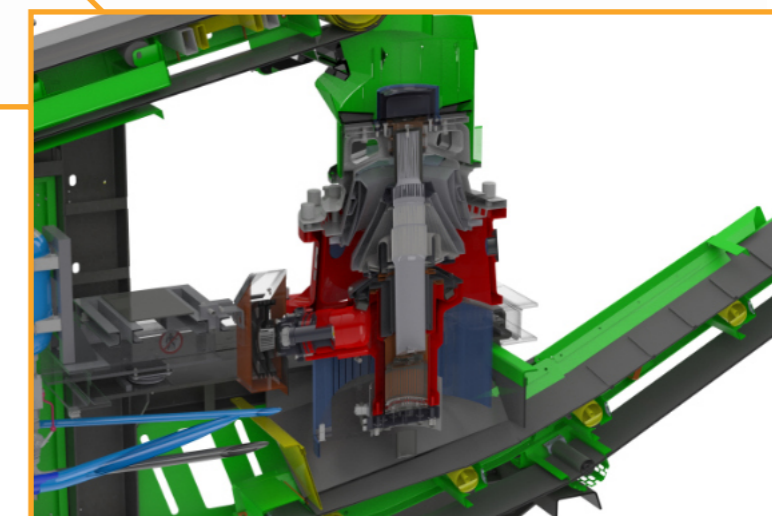

Hopper and feeder

- ✓ large feeding hopper with low tipping height
- ✓ feeder with fluent feeding regulation
- ✓ exchangeable armours

