

# MODEL

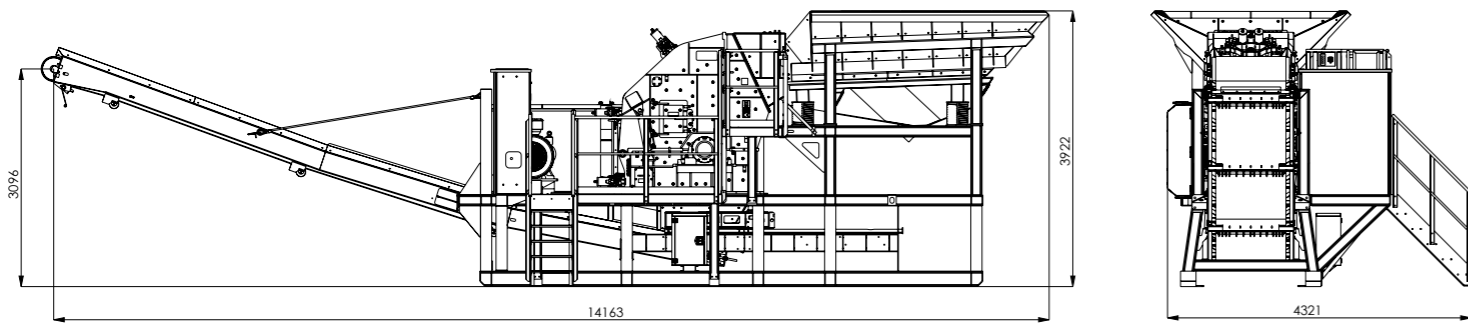

## Operation



## Transport

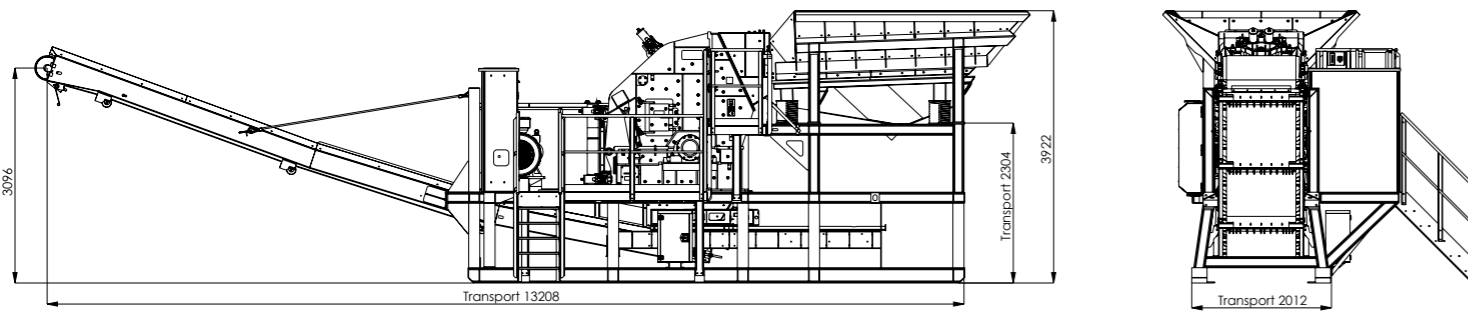

**RESTA OS9**

Semi-mobile impact crusher

- Impact crusher
- Remote control
- Remote data
- Plug in
- Scale
- Eco-friendly
- Automatic feeding
- Lighting
- Diesel electric
- Dust suppression
- Operator shelter

## RESTA s.r.o

### Contact:

Kojetínská 3120/75  
750 02 Přerov  
Czech Republic

+420 581 741 811  
Fax +420 581 299 958  
resta@resta.cz

### Company identification:

CRN: 14616807  
TIN: CZ14616807

GPS: 49.4435458 N, 17.4361281 E

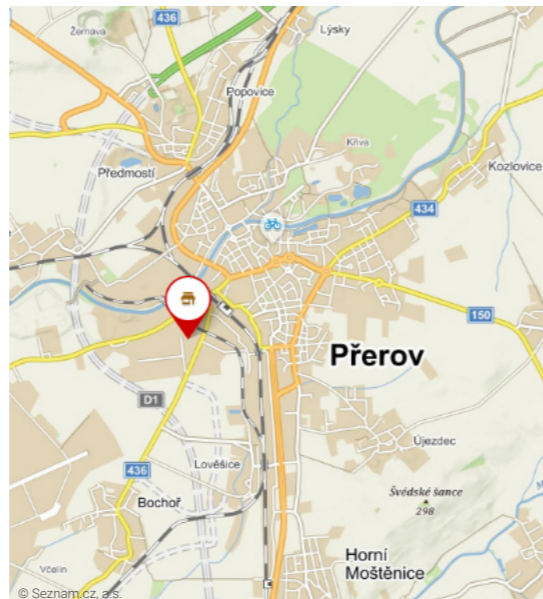

Max. feed size	max. 800 mm diagonally
Final product	0-80 mm
Throughput	80-150 t/h
Hopper	6 m <sup>3</sup>
Weight	23 t

### DESIGNED FOR:

- reinforced concrete
- concrete
- construction waste
- natural aggregate up to 250 (300) MPa

[www.resta.cz](http://www.resta.cz)



RESTA s.r.o.  
CRN: 14616807  
TIN: CZ 14616807

Kojetínská 3120/75  
750 02 Přerov  
Czech Republic

resta@resta.cz  
+420 581 741 811

[www.resta.cz](http://www.resta.cz)



RESTA s.r.o.  
CRN: 14616807  
TIN: CZ 14616807

Kojetínská 3120/75  
750 02 Přerov  
Czech Republic

resta@resta.cz  
+420 581 741 811

[www.resta.cz](http://www.resta.cz)

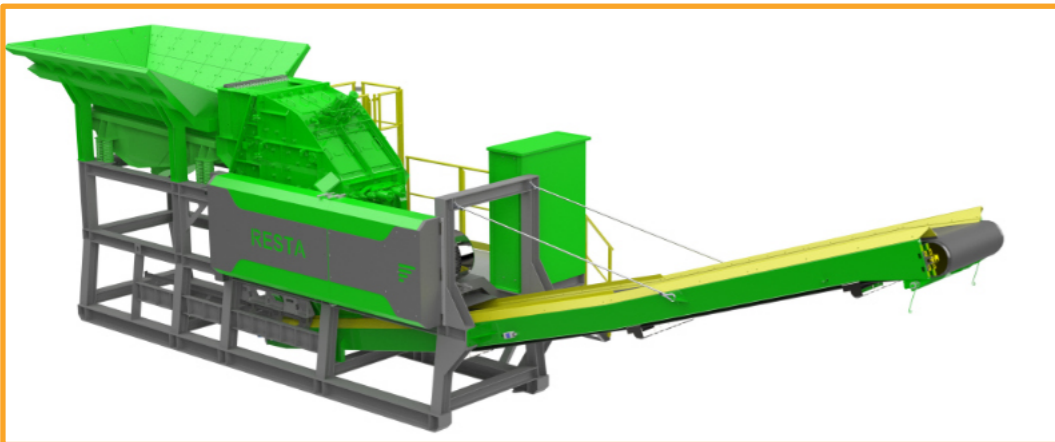

**Magnetic separator**

- ✓ separation of magnetic pieces from the material
- ✓ reversible direction of rotation (discharge to left or right)
- ✓ adjustable overbelt height

**Maintenance and service**

- ✓ clean compact design
- ✓ easy access
- ✓ simplicity

**Operation**

- ✓ semi-automatic control
- ✓ easy and safe access to all operation and service points
- ✓ operator shelter option
- ✓ fine proportional control of tracked undercarriage
- ✓ double-gearred undercarriage

**Electrical distribution**

- ✓ external power supply
- ✓ double sealing of switchboard
- ✓ user -friendly

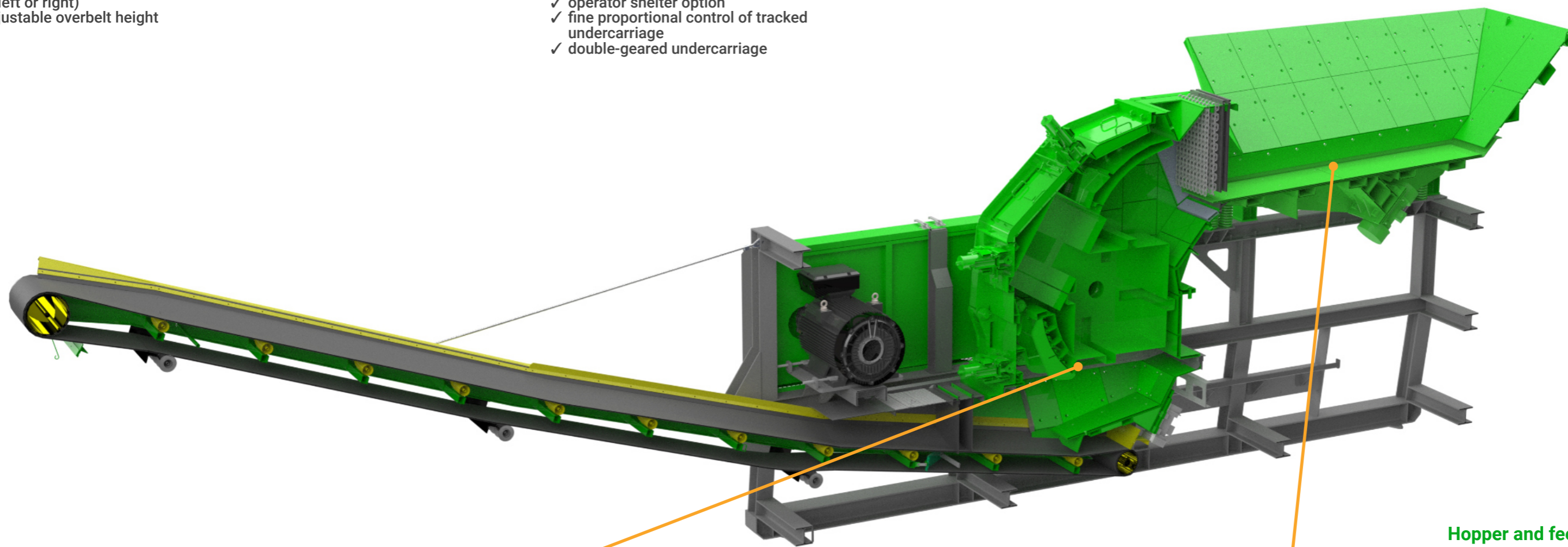

**Hopper and feeder**

- ✓ large feeding hopper with low tipping height
- ✓ feeder with fluent feeding regulation



**Crusher setting**

- ✓ easy setting of impact plates for optimal crushing
- ✓ setting of both ends of the input impact plate
- ✓ option to limit oversized feed pieces by flap setting
- ✓ safe jam release by a hydraulic ram and movable impact plate
- ✓ ceramic impact bars
- ✓ easy impact plates setting without using tools

